



Application

- Can be used to transfer clean water or other liquids similar to water in physical and chemical properties
- Suitable for industrial use and urban water supply, pressure boosting for high buildings and fire fighting, garden irrigation, long-distance water transfer, heating ventilation and air controlling, circulation and pressure boosting for cold and hot water, and supporting equipment etc.

Pump

- Cast iron pump body and support under special anti-rust treatment
- AISI 304 shaft
- Max. liquid temperature: +40°C
- Max. suction: +8 m

Motor

- C&U bearing
- Motor with copper winding
- Built-in thermal protector for single phase motor (≤1.5 kW)
- Insulation class: F
- Protection class: IPX4
- Max. ambient temperature: +40°C

Identification Codes

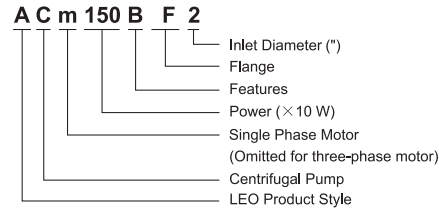

Technical Data

MODEL		POWER		Q (m³/h)														
Single Phase	Three Phase	kW	HP	Q (l/min)	0	12	18	24	30	36	42	48	54	60	66	72	84	96
ACm110BF2	AC110BF2	1.1	1.5	H (m)	19.5	18.5	16.5	13	8.5	-	-	-	-	-	-	-	-	-
ACm110BF3	AC110BF3	1.1	1.5		12.5	12.5	21.1	11.5	10.5	9.5	8.4	7.1	5.5	-	-	-	-	-
ACm150BF2	AC150BF2	1.5	2		22	20.5	18.3	14.5	9.5	-	-	-	-	-	-	-	-	-
ACm150BF3	AC150BF3	1.5	2		14.5	14.3	14	13.5	12.8	12	11.2	9.9	8.4	6	-	-	-	-
ACm220BF3	AC220BF3	2.2	3		17.5	17.3	17.1	16.5	16	15.2	14.2	14.2	11.7	10	7.2	-	-	-
ACm400BF4	AC400BF4	4	5.5		16.5	-	-	16	15.8	15.5	15.3	15.3	15	14.7	14.4	14	13.2	12.1

Dimension

Model	DN1	DN2	L (mm)	W (mm)	H (mm)	L ₁ (mm)	W ₁ (mm)	H ₁ (mm)	D (mm)
ACm110BF2	2"	2"	392	206	270	64.5	166	112	10
ACm110BF3	3"	3"	403	230	300	86	180	120	12
ACm150BF2	2"	2"	392	206	270	64.5	166	112	10
ACm150BF3	3"	3"	403	230	300	86	180	120	12
ACm220BF3	3"	3"	471	230	300	86	180	120	12
ACm400BF4	4"	4"	593	281.5	398	120.5	206	160	16

Hydraulic Performance Curves

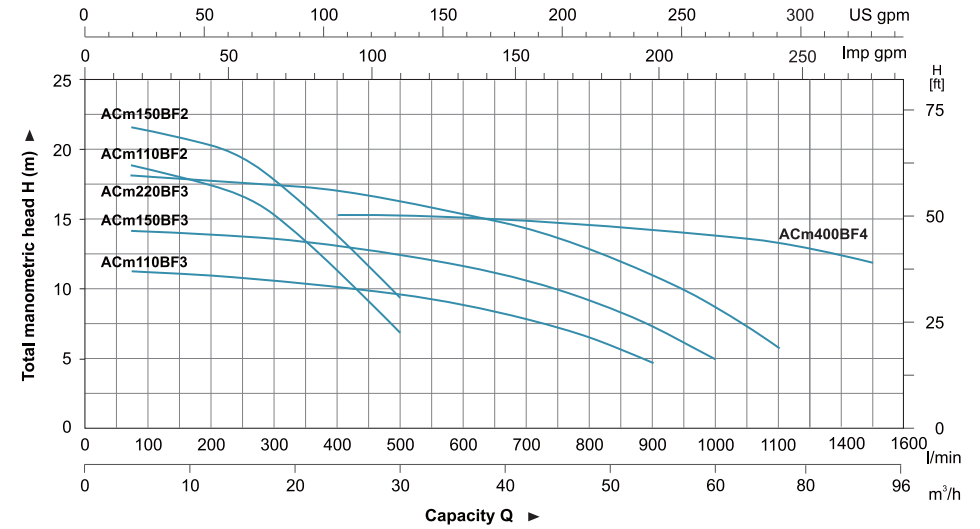

Materials Table

No.	Part	Material
1	Flange	HT200
2	Pump body	HT200
3	Impeller	AISI 304/Brass HT200
4	Mechanical seal	Carbon/Ceramic
5	Oil seal	
6	Support	HT200
7	Bearing	
8	Rotor	
9	Fan cover	PP
10	Fan	PP
11	Rear cover	HT200
12	Stator	
13	Capacitor	
14	Terminal box	PC/ABS

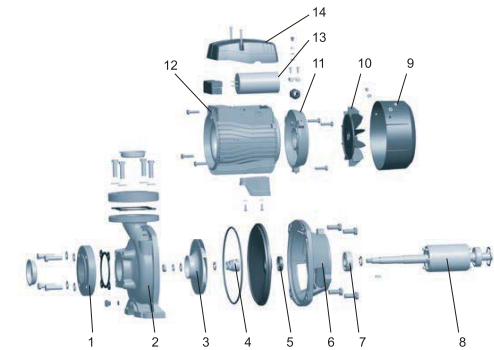

Package Information

Model	GW (Kgs)	L (mm)	W (mm)	H (mm)	Quantity (PCS/20' TEU)
ACm110BF2	22.2	414	230	300	900
ACm150BF2	24	414	230	300	833
ACm110BF3	31.5	433	255	332	634
ACm150BF3	32.5	433	255	332	615
ACm220BF3	40	522	288	332	500
ACm400BF4	72.8	658	330	457	204

